

Operating Manual

Folding Arm² – Door Opener 300 N / 500 N

BA EA-KL²-T(-50) EN 1.3



exemplary picture!

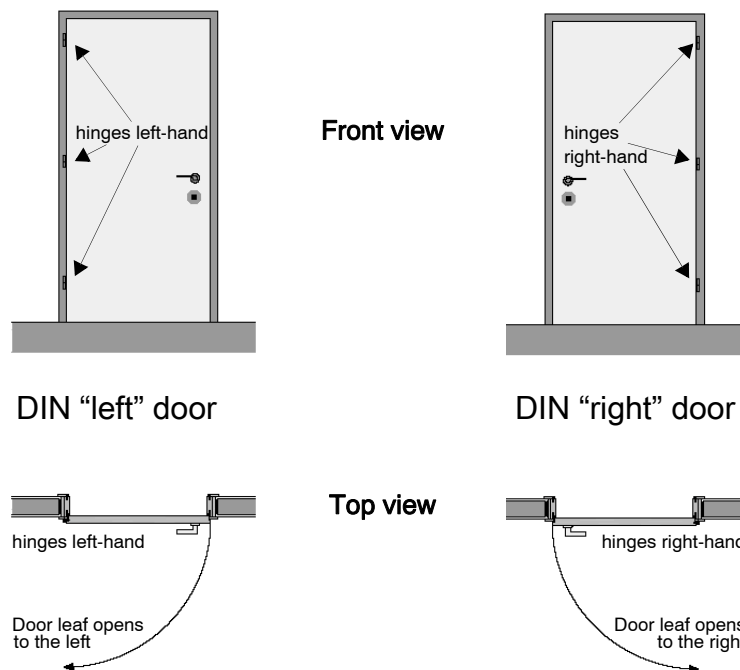

Copyright by SIMON RWA Systeme GmbH
Subject to technical changes and errors.

Only valid in combination with the attached sheet "safety instructions and terms of guarantee"!

Table of Contents

1. In general	3
1.1 Foreword to this manual	3
1.2 Use for the intended purpose	3
1.3 Product description	3
1.4 Functional description	3
1.5 Technical data	3
2. Safety regulations	5
3. Figures	5
4. Mounting	6
4.1 Prepare the door opener	6
4.1.1 Programming run from door opener “Right” (delivery condition) to door opener “Left”	6
4.1.2 Programming run from door opener “Right” to door opener “Left”	7
4.2 Changing the fastening strip from “Right” (delivery condition) to “Left”	7
4.2.1 Fine adjustment of the opening angle	7
4.3 Mounting on the door frame – DIN “Left” door	7
4.4 Mounting on the door frame – DIN “Right” door	8
4.5 Mounting on the door leaf – DIN “Left” door	8
4.6 Mounting on the door leaf – DIN “Right” door	8
4.7 Mounting in the embrasure – DIN “Left” door	8
4.8 Mounting in the embrasure – DIN “Right” door	9
4.9 Visual and functional check	10
4.10 Double doors	10
4.11 Electrical connection	10
4.11.1 Feedback signal	11
4.12 SIMON-Link	11
5. Commissioning	12
6. Care and maintenance	12
7. Troubleshooting	12
8. Appendix	12
8.1 General conditions of business and terms of delivery	12
8.2 Manufacturer’s declaration	12
8.3 EC Manufacturer’s declaration (distributor)	12
8.4 Company addresses	12
8.4.1 Germany	12
8.4.2 Switzerland	12
8.4.3 Hungary	12

In general

1. In general

1.1 Foreword to this manual

This manual has been created for the purposes of proper operation, installation and maintenance by trained, experienced specialist personnel (e. g. mechatronics engineer or electrician) and / or specialist personnel with knowledge involving the installation of electrical devices.

Read the operating manual carefully and follow the prescribed sequence. Retain the operating manual for later use / maintenance. Please precisely observe the pin assignment, the minimum and maximum performance data (see “Technical data”) and the installation instructions. Incorrect usage or improper operation / assembly can cause the loss of system functions and result in damage to property and / or persons.

You will find the following symbols in this manual:



INFO

This information provides you with additional tips!



ATTENTION

This warning draws your attention to potential dangers for the product!



DANGER

This warning draws your attention to possible risks to your life or health!



ENVIRONMENTAL NOTE

This warning draws your attention to potential dangers for the environment!

➤ This is how operating procedures are identified.

↘ Consequences are represented this way.

- *Buttons* or *switches* to be activated are indicated in italics.
- “Displays” are placed in quotation marks.

1.2 Use for the intended purpose

Openers (actuators) serve for the opening of building coverings, which can be installed in walls or in roofs and used for the ventilation of rooms or for the exhaust of smoke. The opening actuator may have to be extended by protective measures in accordance with the risk assessment which is to be carried out.

1.3 Product description

The opening actuator is used in particular with doors that serve as air supply openings for smoke and heat extraction in an emergency. The door and arm are not firmly connected to each other; instead, the door is pushed open by a rolling mechanism. Manual opening of the door is thus possible at any time without restriction. The opening actuator can be used with SHEV and / or ventilation control units from SIMON RWA Systeme[®].

1.4 Functional description

The Folding Arm² Door Opener is an extremely compact opening actuator that functions without spindles, chains or similar actuating elements. The arm rotates around the actuator body. The opening actuator is symmetrical and is easy to re-program from clockwise to anticlockwise rotation via the programming port.

The technical highlights are:

- Compatible with SHEV systems
- Very large opening angles can be implemented
- 616 mm stroke with a force of 300 N / 500 N
- Opening time less than 60 seconds¹
- High-performance gearbox
- Intelligent overload cut-off
 - * Electronic stroke
 - * Soft start
- Intelligent bracket system (enables flexible installation on or in the embrasure)
- Programming interface (SIMON-Link)



- Low current consumption and high efficiency
- Any desired coating possible (RAL, DB)

1.5 Technical data

Table 1: Elektrische Eigenschaften

Actuator type/version	EA-KL ² -T	EA-KL ² -T-50
Rated voltage:	24 V DC	
Permissible rated voltage range:	24 V DC -15%; +15%	
Ripple of rated voltage (Vpp):	max. 500 mV	

1. The declaration is valid under nominal conditions, e. g. rated voltage and / or nominal load.

In general

Actuator type/version	EA-KL ² -T	EA-KL ² -T-50
Undervoltage detection:	Yes	
Rated current ¹ :	1.2 A	1.6 A
Maximum starting current:	OPEN: 1.32 A CLOSE: 0.6 A	OPEN: 1.76 A CLOSE: 0.6 A
Maximum cut-off current in "OPENING" direction:	1.32 A	1.76 A
Maximum cut-off current in "CLOSE" direction:	0.6 A	
Current consumption after cut-off (closed current):	65 mA	
Cut-off via:	built-in electronic overload cut-off	
Protection class:	III	

1. Maximum current consumption with nominal load.

Table 2: Volt-free contact (C1, C2)

Actuator type/version	EA-KL ² -T	EA-KL ² -T-50
Rated voltage:	max. 28 V DC	
Relay contact load:	2 A	

Signal contact in driving direction OPEN

The signal contact (normally open contact NO) is switched in the driving direction OPEN as shown in the following diagram. It is possible, for example in the case of an application with an electric lock (e-opener), to actuate the electric door lock via the signal contact. To this end the blue connecting wire is to be connected to the grey wire. After the signal contact switches, the electric lock (e-opener) is actuated via the black wire (see Figure 7: "Connection example – e-opener" on page 11).

Figure 1: Signal contact diagram – driving direction OPEN

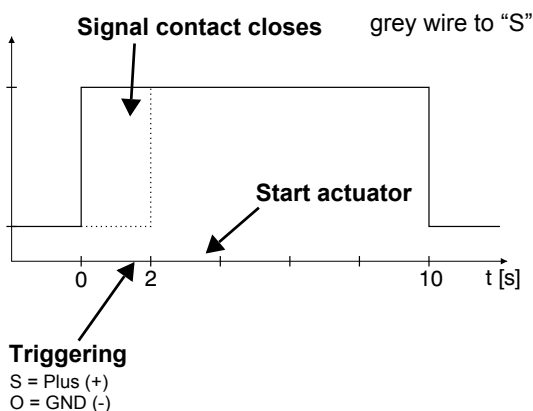

Signal contact in driving direction CLOSE

The normally open contact (NO) is switched in the CLOSE driving direction when the actuator is switched off in the "CLOSE" end position. This means that the signal is stroke-dependent and can be evaluated as a "CLOSE signal" (see Figure 16: "Connection example – lock" on page 11).

Figure 2: Signal contact diagram – driving direction CLOSE

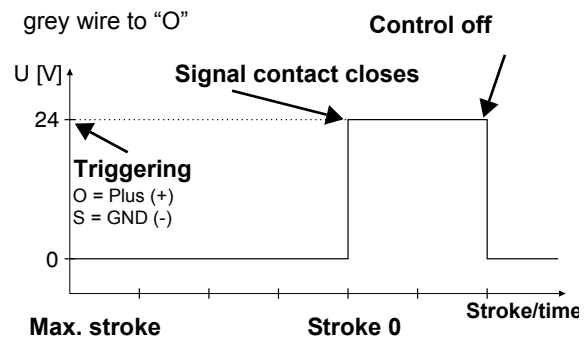

ATTENTION

The maximum contact load (see Table 2: "Volt-free contact (C1, C2)") must not be exceeded.

Table 3: Connection and operation

Actuator type/version	EA-KL ² -T	EA-KL ² -T-50
Silicone connection cable	6 x 0.75 mm ²	
Connection cable length ¹ :	2 m	
Pause when changing direction ² :	min. 500 ms	
Switch-on duration:	ED 50%	
Stability of opening and closing cycles:	> 11,000	
Sound level ³ :	< 70 dB (A)	
Multiple triggering as per prEN 12101-9:	allowed	
Multiple triggering after stop:	allowed	
Maintenance:	See attached sheet "safety instructions and terms of guarantee"!	

1. Optional lengths possible.
2. It is important that we have a zero-voltage part of minimum 500 ms (see Figure 3: "Zero-Voltage part by direction change").
3. Measured at a distance of one metre under normal conditions.

Safety regulations

Figure 3: Zero-Voltage part by direction change

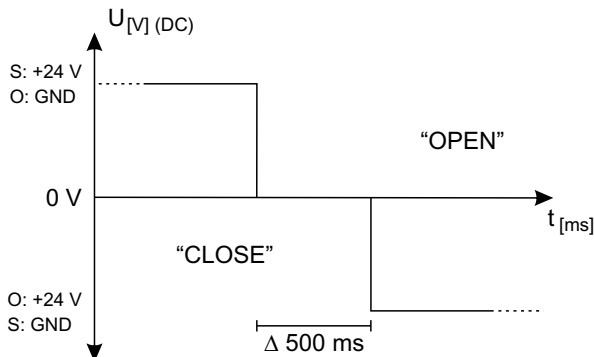

ATTENTION

Voltage stability / quality: Allowed are only clear power downs (voltage drop from 24 V (DC) to 0 V in less than 10 ms).

Especially for transition from primary power supply (main operation) to secondary power supply (backup power supply).

Table 4: Installation and environmental conditions

Actuator type/version	EA-KL ² -T	EA-KL ² -T-50
Rated operating temperature:	20 °C	
Permissible ambient temperature range:	0 - 75 °C	
Temperature stability (SHEV):	300 °C	
Ingress protection:	IP 54	
Usage range:	Central European environmental conditions \leq 2,000 metres above sea level	

Table 5: Approvals and certificates

Actuator type/version	EA-KL ² -T	EA-KL ² -T-50
CE-compliant:	in accordance with EMC directive 2004/108/EC and the low-voltage directive 2006/95/EC	

Table 6: Mechanical characteristics

Actuator type/version	EA-KL ² -T	EA-KL ² -T-50
Nominal load in OPEN:	300 N	500 N
Nominal load in CLOSE ¹ :	50 N	
Nominal locking force:	500 N in CLOSE	
Nominal stroke ² :	616 mm	

Actuator type/version	EA-KL ² -T	EA-KL ² -T-50
Stroke speed with nominal load ³ :	19.2 mm/s	16.4 mm/s
Opening angle	125°	
Material/surface: Lever	Alu E6/EV1 Edelstahl	
Dimensions (L x W x H):	500 x 58 x 122	500 x 60 x 122
Weight:	4.16 kg	4.22 kg

1. Other values are possible as options
2. The nominal stroke can deviate by $\pm 5\%$ due to mechanical damping.
3. Deviation $\pm 5\%$.

Table 7: Accessories

Actuator type/version	EA-KL ² -T	EA-KL ² -T-50
A wide selection of bracket sets is available. The technical data apply only in conjunction with original accessories!		

2. Safety regulations

See attached sheet "safety instructions and terms of guarantee"!

3. Figures

Figure 4: Door opener – EA-KL²-T

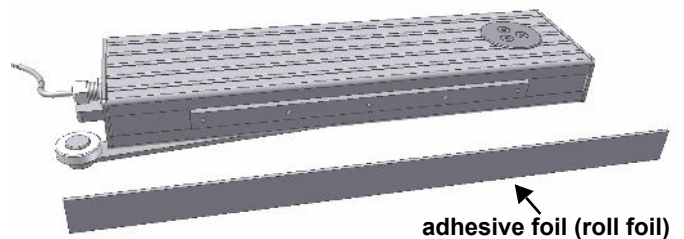

Figure 5: Mounting angle – K-KL²-T-MW

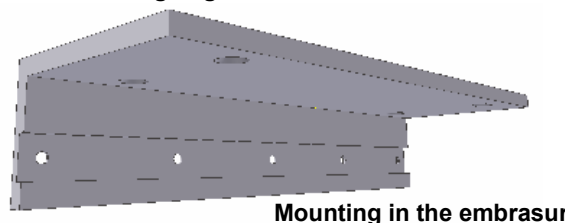
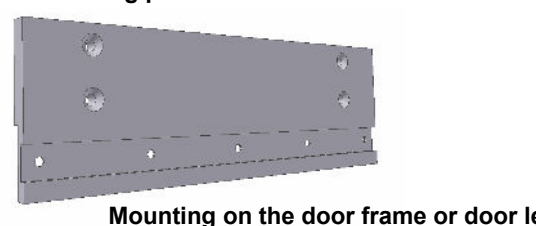

Figure 6: Mounting plate – K-KL²-T-MP



Mounting

4. Mounting

INFO

Information can be found in the ZVEI data sheet 'Power operated windows' (www.simon-rwa.de).

GEFAHR

Mounting may be carried out only by professional personnel (qualified electrician)! All relevant national safety regulations and rules apply to mounting, installation and commissioning. If the installation is not carried out correctly there is a danger of electrocution. It is essential that you adhere to the applicable safety regulations! Pay attention to the valid installation regulations. Incorrect installation can lead to serious injuries.

4.1 Prepare the door opener

Figure 1: Door opener "right"

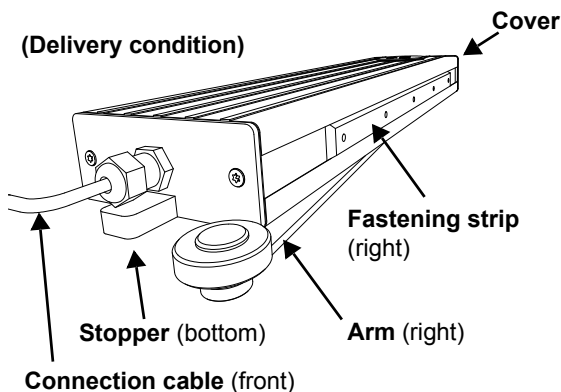

Depending on the application the door opener must be reconfigured and a programming run must be performed.

The following configurations are additionally possible:

- Arm right, fastening strip left.
- Arm left, fastening strip right.
- Arm left, fastening strip left.

INFO

The number of programming cycles is countless. The programming run is necessary for the following application examples.

The door opener can be switched alternatively from „right“ to „left“ and back again via **SIMON Link**[®] — for further information about SIMON Link please visit our website: www.simon-rwa.de.



4.1.1 Programming run from door opener "Right" (delivery condition) to door opener "Left"

- Drive the door opener in the "right" direction.
 - blue to S (+24 V DC)
 - brown to O (GND)
- Let the arm drive up a little.
- Switch off the voltage on S and O.

Figure 2.

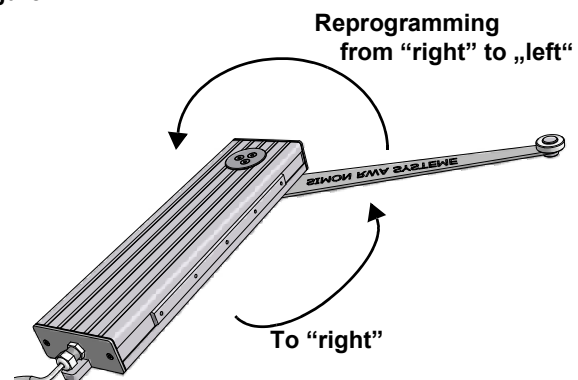

- Connect the red and yellow wires together (programming mode).
- Drive the door opener again.
 - blue to S (plus)
 - brown to O (GND)
- The actuator must now drive in the desired "left" close direction, otherwise drive the actuator in the reverse direction!
- Drive the actuator until it automatically switches off in its end position.
- Switch off the voltage on S and O and disconnect the red wire from the yellow wire (programming port).
- The new running direction is now saved.

Mounting

4.1.2 Programming run from door opener “Right” to door opener “Left”

- As shown in chapter 4.1.1 “Programming run from door opener “Right” (delivery condition) to door opener “Left”” but now with:
 - blue to O (GND)
 - brown to S (+24 V DC)

4.2 Changing the fastening strip from “Right” (delivery condition) to “Left”



ATTENTION

Do not damage the cover seal!

- Remove the cover.
- Pull the fastening strip out of the guide and insert it again on the other side.
- Fit the cover.

Figure 3: Door opener left

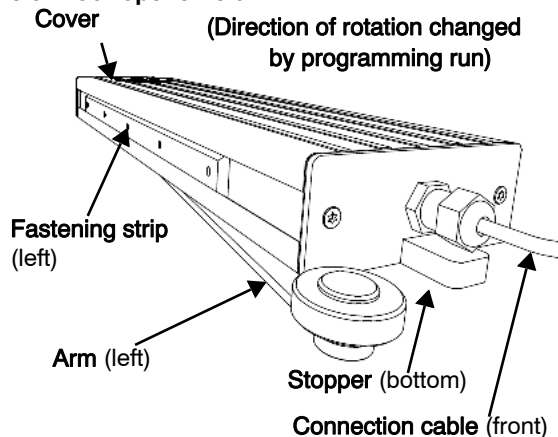

4.2.1 Fine adjustment of the opening angle



INFO

The opening angle can be adjusted by moving the fastening strip!

Figure 4.

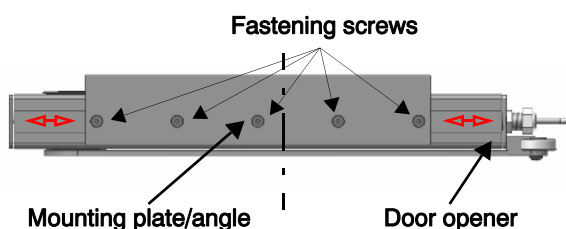

- Loosen the fastening screws.
- Move the door opener to the desired position.
- Tighten the fastening screws with 4 Nm.

4.3 Mounting on the door frame – DIN “Left” door

- Prepare the door opener.
 - Arm left
 - Fastening strip left
- Fasten the door opener to the mounting plate.
- Determine the mounting position (the position depends on the opening angle).
- Mount the mounting plate with the door opener on the door frame.
- After the mounting of the door opener you must check the running surface. Determine the position of the adhesive roll foil. Shorten the adhesive roll foil and stick it on the area of the running surface so that the wheel of the opener arm is always on the foil during an opening process.

Figure 5: Front view – DIN “left” door

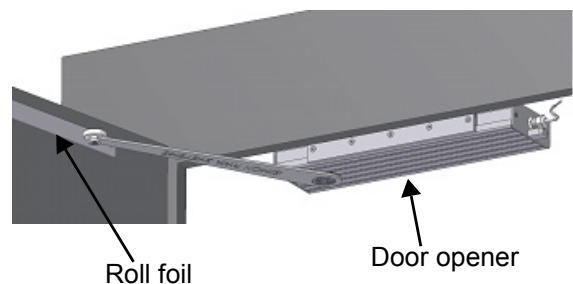
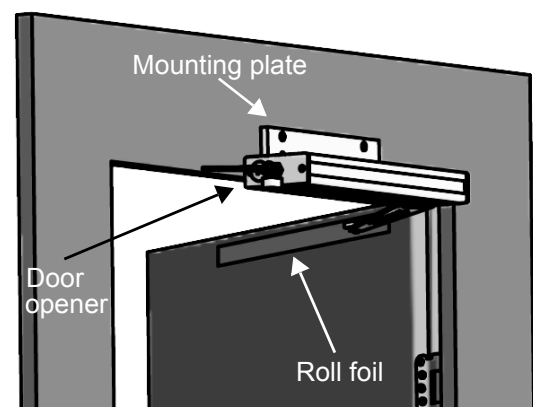

Figure 6: Rear view – DIN “left” door



Mounting

4.4 Mounting on the door frame – DIN “Right” door

- Door opener right.
 - Arm right
 - Fastening strip right
- Mounting as described in chapter 4.3 “Mounting on the door frame – DIN “Left” door” on page 7.

4.5 Mounting on the door leaf – DIN “Left” door

- Prepare the door opener.
 - Arm left
 - Fastening strip left
- Fasten the door opener to the mounting plate.
- Determine the mounting position (the position depends on the opening angle).
- Mount the mounting plate with the door opener on the door leaf.
- After the mounting of the door opener you must check the running surface. Determine the position of the adhesive roll foil. Shorten the adhesive roll foil and stick it on the area of the running surface so that the wheel of the opener arm is always on the foil during an opening process.

Figure 7: Front view – DIN “left” door“

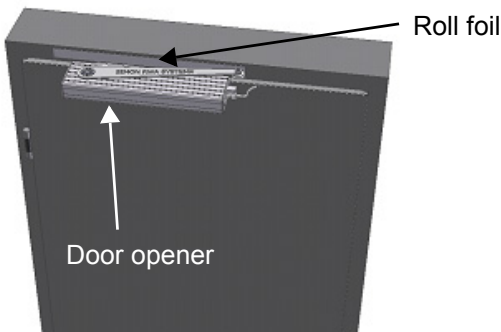
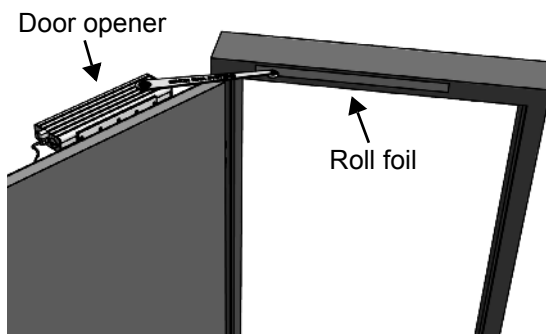

Figure 8: Front view – DIN “left” door



4.6 Mounting on the door leaf – DIN “Right” door

- Use door opener right.
 - Arm right
 - Fastening strip right
- Mounting as described in chapter 4.5 “Mounting on the door leaf – DIN “Left” door”.

4.7 Mounting in the embrasure – DIN “Left” door

4.7.1 Mounting angle at front – arm at bottom (standard)

- Prepare the door opener.
 - Arm left
 - Fastening strip left
- Determine the mounting position (the position depends on the opening angle).
- Mount the mounting angle in the embrasure.
- Fasten the door opener to the mounting angle.
- After the mounting of the door opener you must check the running surface. Determine the position of the adhesive roll foil. Shorten the adhesive roll foil and stick it on the area of the running surface so that the wheel of the opener arm is always on the foil during an opening process.

Figure 9: Front view – DIN “left” door

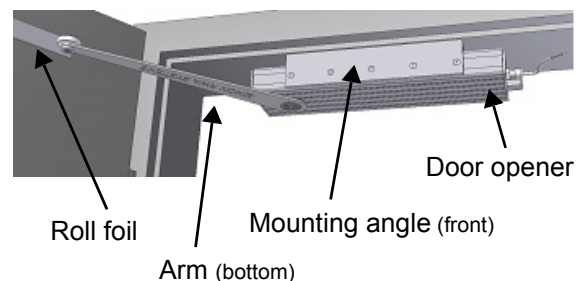
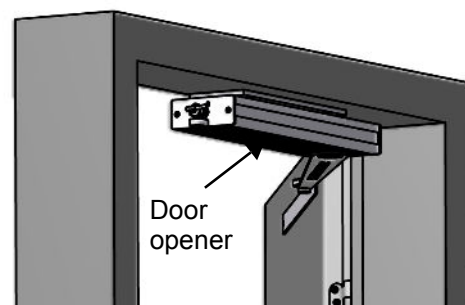

Figure 10: Rear view – DIN “left” door



Alternatively the following mounting variants can be selected for DIN “left” doors:

- Mounting angle at rear – arm at bottom
- Mounting angle at rear – arm at top

Mounting

4.7.2 Mounting angle at rear – arm at bottom

- Prepare the door opener.
 - Arm left
 - Fastening strip right
- Determine the mounting position (the position depends on the opening angle).
- Mount the mounting angle in the embrasure.
- Fasten the door opener to the mounting angle.
- After the mounting of the door opener you must check the running surface. Determine the position of the adhesive roll foil. Shorten the adhesive roll foil and stick it on the area of the running surface so that the wheel of the opener arm is always on the foil during an opening process.

Figure 11: Front view – DIN “left” door

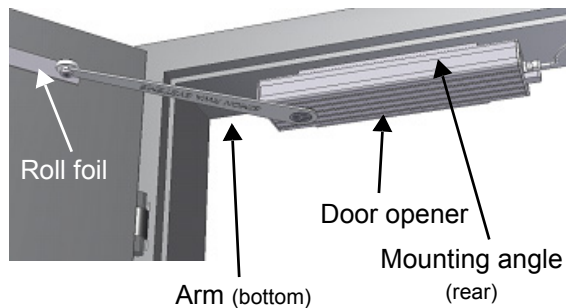
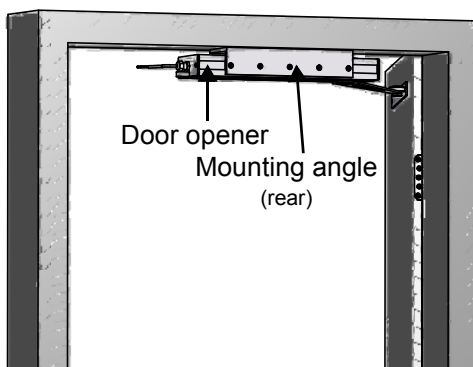

Figure 12: Rear view – DIN “left” door



4.7.3 Mounting angle at rear – arm at top

- Prepare the door opener.
 - Arm right
 - Fastening strip left
- Determine the mounting position (the position depends on the opening angle).
- Mount the mounting angle in the embrasure.
- Fasten the door opener to the mounting angle.

- After the mounting of the door opener you must check the running surface. Determine the position of the adhesive roll foil. Shorten the adhesive roll foil and stick it on the area of the running surface so that the wheel of the opener arm is always on the foil during an opening process.

Figure 13: Front view – DIN “left” door

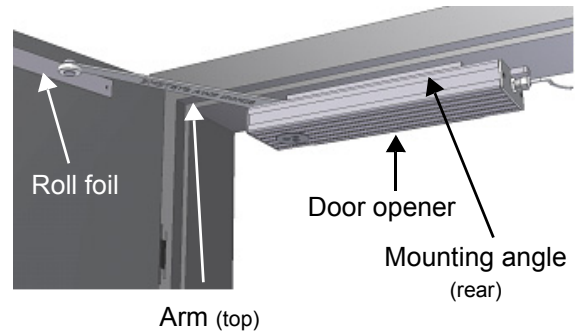
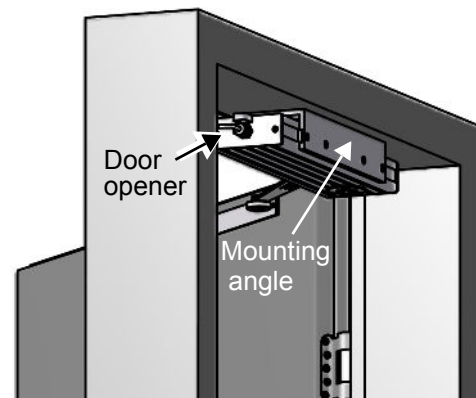

Figure 14: Rear view – DIN “left” door



4.8 Mounting in the embrasure – DIN “Right” door

4.8.1 Mounting angle at front – arm at bottom (standard)

- Use door opener right (delivery condition).
 - Arm right
 - Fastening strip right
- Mounting as described in chapter 4.7.1 “Mounting angle at front – arm at bottom (standard)” on page 8.

4.8.2 Mounting angle at rear – arm at bottom

- Prepare the door opener.
 - Arm right
 - Fastening strip left
- Mounting as described in chapter 4.7.2 “Mounting angle at rear – arm at bottom” on page 9.

Mounting

4.8.3 Mounting angle at rear – arm at top

- Prepare the door opener.
 - Arm left
 - Fastening strip right
- Mounting as described in chapter 4.7.3 “Mounting angle at rear – arm at top” on page 9.

4.9 Visual and functional check

- Finally, carry out a visual and functional check.

4.10 Double doors

The factory-provided two seconds start delay of the actuator after triggering in OPENING direction (see Figure 1: “Signal contact diagram – driving direction OPEN” on page 4) can be set to a higher value so that two actuators mounted on a double door start with a time offset. Thus, a safe time-delayed opening of the door is ensured.

INFO

For further information about **SIMON Link**[®] please visit our website: www.simon-rwa.com.



4.11 Electrical connection

DANGER

Please check the complete system before connecting to the 24 V DC supply.

INFO

We recommend that a test run be carried out using a suitable mobile power supply (including control unit, no battery alone). This allows simple and fast reaction to malfunctions.

ATTENTION

Do not earth the electrical connection.
The actuator may only be run with 24 V DC protective low voltage!

- Connect cables in accordance with the connection plan.

Figure 15: Connection plan

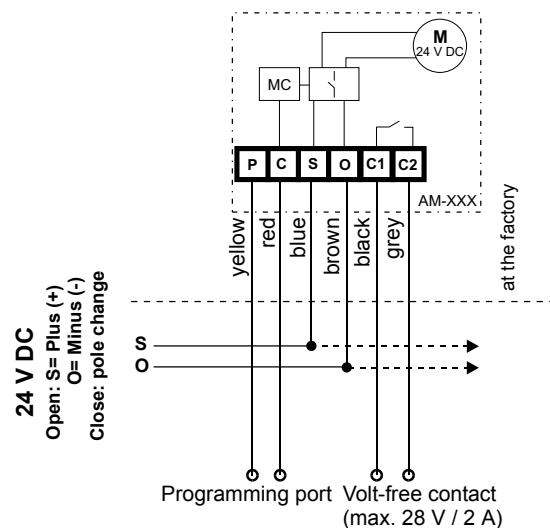

Mounting

4.11.1 Feedback signal

Necessary, for example, for control purposes, running displays, e-opener, locking, etc.



ATTENTION

In the case of using an e-opener you need a diode nearby the e-opener, e. g. 1N4004!

Figure 7: Connection example – e-opener

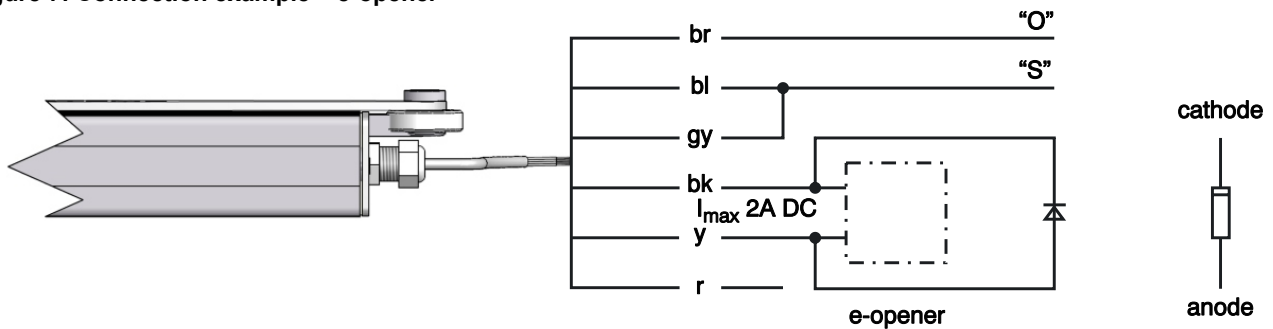
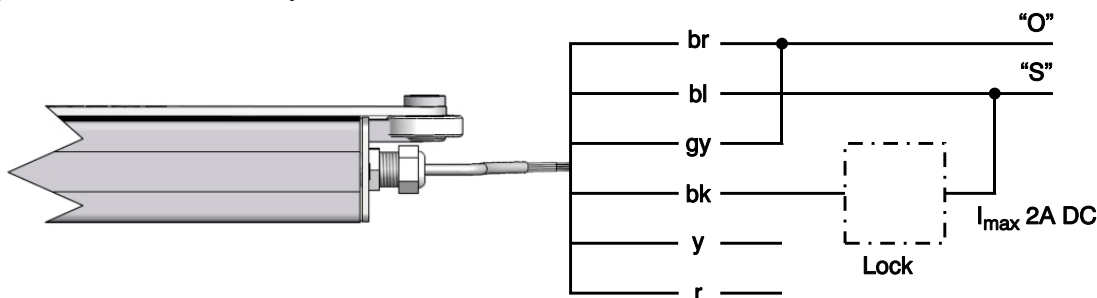

Figure 16: Connection example – lock



4.12 SIMON-Link



INFO

To set parameters via SIMON link you need a USB-200 service cable and the supporting software. For more information visit www.simon-rwa.de.



The actuator has a parameterisation port, at via SIMON-Link

- the stroke can be limited electronically,
- forces (cut-off current) in "OPEN" direction can be adjusted,
- the start delay can be adjusted,
- the driving direction can be changed,

- a detailed status report of the actuator can be read out.
- To read out data via SIMON-Link or to parameterise the actuator must be powered externally, ideally in the direction "CLOSE".

Figure 8: Parameterisation port for SIMON-Link

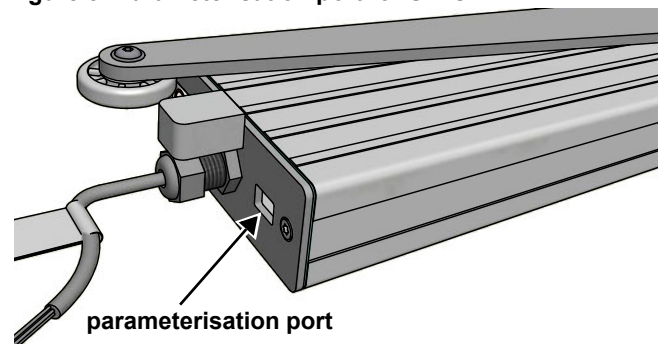

Commissioning

5. Commissioning

See attached sheet “safety instructions & guarantee conditions”!

6. Care and maintenance

See attached sheet “safety instructions & guarantee conditions”!

7. Troubleshooting

Table 8: Overview of faults

Malfunction	Possible causes	Failure correction
The actuator does not work	- No mains voltage - Connection cable defective	- Check the fuse and the supply cable - Check the connection cable
The actuator runs in the wrong direction	- Connecting terminals “+/-” wrong way round S = blue; O = brown - no programming run performed	- Swap connecting terminals “S” and “O” - Perform a programming run

8. Appendix

8.1. General conditions of business and terms of delivery

The currently valid conditions for products and services of the electrical and electronics industry (green delivery terms) apply for deliveries and services, including the supplementary clause “Extended retention of title”. These are published by ZVEI Frankfurt. If you are not familiar with these, we would be happy to send them to you. The agreements are also available for download at www.simon-rwa.de.

Passau is the established legal venue.

8.2 Manufacturer’s declaration



We hereby declare the conformity of the product with the applicable guidelines. The declaration of conformity can be viewed in the company and will be delivered upon request. This declaration certifies conformity with the directives mentioned, but gives no guarantee of characteristics. This declaration becomes invalid following a change that has been made without our consent.

8.3 EC Manufacturer’s declaration (distributor)

The installer is responsible for the proper mounting or commissioning and the preparation of the declaration of conformity in accordance with the EU directives.



INFO

The installer is responsible for affixing the CE marking. The CE-marking is to be affixed in a visible place!

8.4 Company addresses

8.4.1 Germany

Simon RWA[®] Systeme GmbH
Medienstr. 8
D – 94036 Passau
Tel: +49 (0)851 98870 - 0
Fax: +49 (0)851 98870-70
E-mail: info@simon-rwa.de
Internet: www.simon-rwa.de

8.4.2 Switzerland

Simon RWA[®] Systeme AG
Allmendstrasse 8
CH – 8320 Fehraltorf
Tel: +41 (0)44 956 50 30
Fax: +41 (0)44 956 50 40
E-mail: info@simon-rwa.ch
Internet: www.simon-rwa.ch

8.4.3 Hungary

Simon RWA[®] Systeme Kft.
Vezér utca 147 / D, 3rd Floor, No. 17
H – 1148 Budapest
Tel: +36 (0)30 522 0424
E-mail: info@simon-rwa.hu

Your **Simon RWA** partner: